

AN-5

TRANSFORMER-BASED PHONE LINE INTERFACES (DAA, FXO)

By Joe Randolph

Preface

This is an expanded version of an earlier application note titled “Low Cost Telephone Line Interface (DAA, FXO),” which was originally published as Midcom Technical Note TN #98. Midcom TN #98 is also posted on the Randolph Telecom web site as AN-4.

The original TN #98 was written because Midcom received frequent requests from customers for a reference design that showed how to build an inexpensive, reliable phone line interface. The “wet” transformer circuit described in TN #98 has been well received and has been used by many designers for the basic, low cost applications it is intended for.

The limitations of the wet transformer circuit were described in TN #98 and reference was made to addressing these with a “dry” transformer, but a suitable dry transformer circuit was not shown. The purpose of this application note is to expand TN #98 by adding a basic dry transformer circuit.

Another section has been added that describes the general characteristics of transformer-based DAA-FXO circuits and how they compare to silicon DAA-FXO solutions.

Introduction

There are numerous applications where a product must connect to a conventional telephone line. Examples include:

- Telephones
- Data Modems
- Fax machines
- Set top boxes
- Alarm dialers
- Point of sale terminals
- Remote monitoring and control

When the application is a modem, the phone line interface is typically called a DAA (Data Access Arrangement), while the term usually used for voice applications is FXO (Foreign Exchange Office). The basic functionality is the same, although different performance requirements sometimes apply. For the purposes of this document, we will refer to the interface as a “DAA-FXO” interface.

The interface to an analog phone line is primarily an analog circuit function. These days most designers are more comfortable with digital circuit design, so the task of designing a phone line interface can introduce unfamiliar considerations such as isolation, balance, return loss, distortion, echo, power cross, and lightning immunity. Furthermore, most countries impose specific regulatory requirements on phone line interfaces. These requirements are often difficult for uninitiated readers to understand.

This article describes two simple, robust, low cost phone line interfaces that can be used for a wide variety of applications:

- 1) A very basic, low cost design that uses a so-called “wet” transformer
- 2) A basic, higher performance version that uses a so-called “dry” transformer.

The intent of this article is to provide two complete designs, including schematics, parts lists and layout guidelines, so that even a designer who is inexperienced with phone line interface design can have a good chance of getting it right the first time.

Comparison of Transformer-Based and Silicon DAA-FXO Circuits

Transformer-based DAA-FXO circuits have been in use for over 50 years. Early implementations tended to use large transformers, but recent changes in requirements and transformer technology have made the transformers much smaller. In particular, “dry” transformers are now available in very small packages.

Over the last 15 years, various vendors have introduced transformerless DAA-FXO circuits that use silicon chips, combined with an alternate form of isolation (capacitive, optical, or pulse transformer), to implement the DAA-FXO circuit in a smaller form factor. These are generally referred to as “silicon DAAs.” Current vendors include Silicon Labs, Clare, Integration Associates, and Teridian Semiconductor, plus modem chip set vendors Agere and Conexant.

It is not the purpose of this article to provide a detailed comparison of transformer DAA-FXO circuits and all the various silicon DAA-FXO circuits. There are many differences, even among the silicon versions, that might make one particular solution best suited for a given application. However, certain general observations can be made regarding how transformer solutions compare to silicon solutions.

Performance Advantages of Transformer-Based DAA-FXO Circuits

There are certain performance advantages that transformer based DAA-FXO circuits typically have over the various silicon implementations. The following characteristics are common to both of the transformer circuits presented here:

- Outstanding lightning immunity
- Outstanding immunity to 60 Hz “power cross” faults
- Excellent immunity to conducted RF interference, as tested by EN 55024
- Ability to operate on extremely low loop current
- Ability to transmit at high levels, even with low loop current
- Outstanding balance and common mode 60 Hz immunity, for low noise and hum

Performance Advantages of Silicon DAA-FXO Circuits

- Lowest absolute size, especially in component height
- Easier monitoring of line status, such as line-in-use and parallel phone pickup
- Easier to configure parameters for worldwide regulatory compliance

Cost Comparison

It is difficult to make general statements about how the options compare, because pricing on components varies over time. Another factor is that some of the silicon DAA-FXO circuits contain an embedded codec function, while others do not. When comparing costs for various options, it is important to draw up a representative schematic that implements all of the required features, and then calculate the total bill of materials cost and the board area for the entire solution.

In general, the wet transformer DAA-FXO circuit is likely to be the lowest cost solution for the basic functions. The dry transformer circuit will cost slightly more. The various silicon DAA-FXO circuits are likely to have costs roughly comparable to the dry transformer circuit, depending on the specific combination of features.

Summary

There is no single DAA-FXO solution that is best for every application, so the product design engineer must identify the key requirements of the application and then compare how well the various options address those requirements.

In general, though, a well designed transformer-based solution will provide the best overall performance at a competitive cost. If any of the three advantages listed above for silicon DAA-FXO circuits are critical for the application, a silicon DAA-FXO may be the best solution.

To perform the selection process methodically, the recommended sequence is to start with the wet transformer circuit as the default choice and then progress in the following order if that option is not suitable for the application:

- 1) Wet transformer circuit
- 2) Dry transformer circuit
- 3) Silicon circuit (many variations to choose from)

Two Types of Transformer DAA-FXO Circuits, “Wet” and “Dry”

There are two basic types of transformers used in DAA-FXO circuits, typically referred to as “wet” transformers and “dry” transformers.

“Wet” is a telecom term indicating that the DC loop current from the phone line passes through the primary winding of the transformer. This is the simplest form of transformer-based DAA-FXO circuit, and typically has the lowest cost.

“Dry” is a telecom term indicating that DC loop current does not flow through the transformer. In a dry transformer circuit, a blocking capacitor is used to prevent DC from passing through the transformer winding, and the DC loop current is diverted through a separate DC holding circuit. Due to the need

for this additional circuitry, dry transformer circuits are more expensive than wet transformer circuits, but they have certain advantages that can be useful for some applications. In the notes that follow, both wet and dry transformer circuits will be discussed and their characteristics will be compared.

Wet Transformer DAA-FXO Circuit

Figure 1 shows a basic DAA-FXO circuit that uses a so-called “wet” transformer. The wet circuit described here can be enhanced to support caller ID, loop current detection, and ground start, but those functions are not included in the Figure 1 schematic.

Wet transformer circuits are simple, rugged, and inexpensive, but they have some limitations. The DC loop current, which typically ranges from 20 to 100 mA, must be tolerated by the transformer without causing the core to saturate. This is accomplished by using a comparatively large transformer core and gapping the core to prevent saturation. As a result, wet transformers tend to be larger than their dry counterparts, and their shunt inductance is much lower. The lower shunt inductance makes impedance matching more difficult, and the silicon steel typically used for the core material places limits on the distortion performance.

However, the extremely low cost and the high reliability of the wet transformer circuit make it the perfect choice for some applications. In fact, wet transformer circuits typically offer the lowest possible cost and highest reliability of any available technology for phone line interfaces. Because of these attributes, a wet transformer design should be used as the default choice unless certain product requirements render it unsuitable. Following are the key considerations where a wet transformer design would **not** be suitable:

Size

Wet transformers are typically larger than their dry counterparts. The Midcom 82111 transformer used in this design has a footprint of .908 by .945 inches (about 23 mm by 24 mm), and is .490 inches tall (about 13 mm). This may not be acceptable for applications with severe space constraints.

Impedance Matching for Certain International Applications

The AC impedance presented to the phone line (usually measured as the parameter “return loss”) is subject to regulatory requirements in some countries. There are no longer any regulatory requirements for return loss in North America or the European Union, but some countries continue to have requirements for this parameter. The wet transformer design presented here meets the requirements for most countries, but Australia, Brazil, India, and South Africa are some notable exceptions. In China, the return loss of the wet transformer design meets the regulatory requirements for modems and fax machines, but not for voice equipment.

Distortion for Certain Modem Applications

This wet transformer design is not suitable for high speed, full duplex modems that use digital echo cancellers. Echo canceling modems such as ITU standards V.32bis, V.34bis (full duplex mode), and V.90 require extremely low transmit distortion that is more easily achieved with a suitable dry transformer.

However, the wet transformer design presented here will work very well for conventional split band modems such as ITU standards V.21 (300 bps), V.22 (1200 bps), and V.22bis (2400 bps). It will also work well for any fax modem, including V.34bis (33,600 bps), since fax modems are half duplex and do not use digital echo cancellers.

Summary of Applicability Considerations

In summary, the low cost design presented here is suitable for applications where the requirements for transformer size, AC impedance matching, and distortion are within the limits imposed by the use of an inexpensive wet transformer. All of these limitations can be overcome by using a dry transformer circuit, but the dry transformer circuit adds some cost and is more complicated to design.

Circuit Description for Wet Transformer DAA-FXO

Referring to Figure 1, the central element of the line interface is T1, the Midcom 82111 transformer. T1 is used to couple the analog transmit and receive signals across the isolation barrier.

U2 is a solid state relay that will put the interface in the active, offhook state when the /OFFHOOK input is pulled low, closing the relay. Note that the /OFFHOOK control line must sink about 3 mA in the active-low state, and that it must be pulled to +5V when the interface is in the idle, onhook state.

Opto isolator U3 is connected so that the output /RINGDET will produce a pulse train of negative-going pulses when a ringing signal of more than 20 VRMS is applied to tip/ring. The pulse train will have the same frequency as the applied ringing signal (typically 15 to 55 Hz).

The output signal on /RINGDET can have slow edges, and for ring signals in the range of 10 to 20 VRMS the logic low levels will be invalid. For these reasons, the /RINGDET signal should probably be polled rather than connected to an interrupt. To avoid false ring detection caused by transients on tip/ring, the software that reads the /RINGDET output should debounce the signal by looking for three consecutive transitions that fall within the range of 15 to 55 Hz.

Surge protector E1 protects against lightning surges and overvoltages that appear across tip/ring. Diode D1 clamps any residual energy that couples through the transformer.

Fuse F1 is generally required in the USA and Canada to pass the M1 overvoltage test in UL/CSA 60950. This fuse is not required in other countries, and under certain circumstances it is not required for UL/CSA 60950. Any fuse used in this location should open cleanly for the M1 test in UL/CSA 60950, and should tolerate lightning surges of 100 amps peak, 10x1000 uS duration. The fuses listed in the bill of materials meet these requirements. There are several alternative choices including some in surface mount form.

The LMV822 op amp U1A provides the transmit driver for analog transmit signals, and U1B provides the receive amplifier. Note that the LMV822 has a rail-to-rail output stage that can drive 600 ohm loads, which is an important feature for the transmit driver. Any substitutions for the LMV822 should be made with this requirement in mind.

The transmit and receive gains are set to 0 dB. This means that signals applied between ground and TRANSMIT will appear with the same amplitude across a 600 ohm load on the phone line, and signals applied across the phone line's tip/ring leads will appear with the same amplitude between the RECEIVE output and ground.

Resistors R6 and R10 provide a modest amount of cancellation of the transmit signal from the receive signal (typically called trans-hybrid loss). Any changes made to the receive gain will require a re-optimization of the value for R10.

The AC impedance presented to the phone line has been set to 600 ohms. The two components that dominate the impedance are R4 and the transformer. Changes to either of these components will affect the AC impedance, the transmit/receive gains, and the trans-hybrid loss.

Lightning immunity with the specified components is excellent. Differential lightning surges (tip to ring) are current limited by U2 and shunted through E1. Immunity to common mode lightning (tip/ring to earth ground) is provided by the isolation barrier that passes through T1, U2, and U3.

Dry Transformer DAA-FXO Circuit

Figure 2 shows a DAA-FXO circuit that uses a so-called “dry” transformer. As noted above, “dry” is a telecom term that means that no DC loop current flows through the transformer winding. Capacitor C11 blocks DC current from passing through the transformer, diverting it through the DC hold circuit inside the red dashed line. Removing the DC current from the transformer winding allows the Midcom 671-8489 dry transformer to be dramatically smaller than the Midcom 82111 wet transformer. Certain performance parameters of the transformer are also improved. The dry transformer circuit in Figure 2 has the following improvements over the wet transformer circuit in Figure 1:

- Smaller size, especially in height
- Improved AC impedance matching for meeting certain international requirements
- Improved trans-hybrid loss for data and VOIP applications that use digital echo cancellers
- Reduced transmit distortion

It is important to remember that many DAA and FXO applications do not require any of the above improvements. Examples typically include low speed modems, fax machines, alarm dialers, and set top boxes. For any application where the above features are not needed, the wet transformer circuit would provide the lowest cost solution.

The dry circuit described here can be enhanced to support caller ID, loop current detection, and ground start, but these functions are not included in the Figure 2 schematic.

Brief Description of Dry Transformer Improvements

Smaller Size

The Midcom 671-8489 dry transformer used here is much smaller than the Midcom 82111 wet transformer. The entire circuit shown here can be implemented in a board area of about one square inch (6.5 square centimeters) on a 2-sided board. Since the dry transformer requires a DC hold circuit that is not needed for the wet transformer, the difference in board area compared to the wet transformer circuit is not substantial. The main difference with the dry transformer is the reduced height of .177 inches (4.5 mm) for the dry transformer compared to .490 inches (12.45 mm) for the wet transformer.

Improved AC Impedance Matching

The advantage of keeping DC current out of the transformer is that the transformer can use a high permeability, ungapped core. This provides much higher shunt inductance that allows the transformer to readily match any required AC impedance, achieving return loss figures in excess of 20 dB across the 300 to 3400 Hz voice band. In the circuit presented here, the AC impedance has been set to 600 ohms, but this transformer can support any of the reference impedances specified worldwide.

Improved Trans-Hybrid Loss

Trans-hybrid loss (THL) is the extent to which the signal transmitted by the DAA-FXO circuit is cancelled out from the incoming signal presented at the RECEIVE output. In some applications, THL is not important at all, but for high speed modems and VOIP (Voice Over Internet Protocol) applications, digital echo cancellers are used to enhance the overall THL. These cancellers typically require a minimum of 6 dB THL in the analog circuitry of the DAA-FXO circuit, under any “normal” line condition that can be encountered in the field. The wet transformer circuit in Figure 1 does not provide the minimum 6 dB THL for all line conditions, but the dry circuit in Figure 2 meets the requirement easily. In addition, the dry circuit typically achieves better average THL over the full range of line conditions than the wet circuit.

Reduced Transmit Distortion

The digital echo cancellers used in high speed data modems are very sensitive to distortion in the signal transmitted onto the phone line. While the distortion of the Midcom 82111 wet transformer is low enough for voice applications and full duplex data modems up to the 2400 bps ITU V.22bis standard, it becomes a problem for the echo canceling full duplex data modem ITU standards V.32bis, V.34bis, and V.90. The Midcom 671-8489 dry transformer in the circuit of Figure 2 has much lower distortion than the Midcom 82111, and is generally suitable for V.32bis and V.34bis applications. It can also be used for V.90 applications, but if performance is critical, these applications may benefit from a different dry transformer with even lower distortion. Note that some component values in the circuit shown here would have to be re-optimized if the transformer is changed.

Circuit Description for Dry Transformer DAA-FXO

Referring to Figure 2, the primary difference from the circuit of Figure 1 is the DC hold circuit that must be added for the Midcom 671-8489 dry transformer. A DAA-FXO interface must draw DC loop current from the phone line in the active (offhook) state. In the wet transformer circuit, DC loop current flows directly through the transformer winding. In the circuit of Figure 2, the DC current is blocked by capacitor C11 and diverted through the DC hold circuit indicated by the red dotted line.

The electrical characteristics of the DC hold circuit are roughly comparable to a large inductor of about 10 Henrys. The DC hold circuit presents a low effective resistance to the DC loop current, but a high AC impedance to the voice band signals on the phone line. The “inductor” characteristic is implemented by Q2, R16, R17, R18, and C12. This arrangement is sometimes called a “gyrator” circuit because it transforms capacitor C12 into something with the characteristics of a large inductor. The components Q1, C13, R13, and R14 are used to improve the DC transient response of the DC hold circuit. In some applications they are not needed.

Surge diode D4 limits the voltage across the DC hold circuit during surge events. Capacitor C14 helps attenuate RF noise that might otherwise get into the DC hold circuit.

Aside from the above changes, the rest of the dry transformer circuit is very similar to the wet transformer circuit. The following description of the remaining circuit elements in the dry transformer circuit closely matches the description of the corresponding parts of wet transformer circuit.

U2 is a solid state relay that will put the interface in the active, offhook state when the /OFFHOOK input is pulled low, closing the relay. Note that the /OFFHOOK control line must sink about 3 mA in the active-low state, and that it must be pulled to +5V when the interface is in the idle, onhook state.

Opto isolator U3 is connected so that the output /RINGDET will produce a pulse train of negative-going pulses when a ringing signal of more than 20 VRMS is applied to tip/ring. The pulse train will have the same frequency as the applied ringing signal (typically 15 to 55 Hz).

The output signal on /RINGDET can have slow edges, and for ring signals in the range of 10 to 20 VRMS the logic low levels will be invalid. For these reasons, the /RINGDET signal should probably be polled rather than connected to an interrupt. To avoid false ring detection caused by transients on tip/ring, the software that reads the /RINGDET output should debounce the signal by looking for three consecutive transitions that fall within the range of 15 to 55 Hz.

Surge protector E1 protects against lightning surges and overvoltages that appear across tip/ring. Diode D1 clamps any residual energy that couples through the transformer.

Fuse F1 is generally required in the USA and Canada to pass the M1 overvoltage test in UL/CSA 60950. This fuse is not required in other countries, and under certain circumstances it is not required for UL/CSA 60950. Any fuse used in this location should open cleanly for the M1 test in UL/CSA 60950, and should tolerate lightning surges of 100 amps peak, 10x1000 uS duration. The fuses listed in the bill of materials meet these requirements. There are several alternative choices including some in surface mount form.

The LMV822 op amp U1A provides the transmit driver for analog transmit signals, and U1B provides the receive amplifier. Note that the LMV822 has a rail-to-rail output stage that can drive 600 ohm loads, which is an important feature for the transmit driver. Any substitutions for the LMV822 should be made with this requirement in mind.

The transmit and receive gains are set to 0 dB. This means that signals applied between ground and TRANSMIT will appear with the same amplitude across a 600 ohm load on the phone line, and signals applied across the phone line's tip/ring leads will appear with the same amplitude between the RECEIVE output and ground.

Resistors R6 and R10 provide some cancellation of the transmit signal from the receive signal (typically called trans-hybrid loss, or THL). Any changes made to the receive gain will require a re-optimization of the value for R10.

The values shown for R6 and R10 optimize the THL for a termination of 600 ohms on the phone line. For a 600 ohm termination, the THL will be better than 20 dB. While it is customary in many applications to optimize the THL for a 600 ohm termination, the fact is that the impedance of actual phone lines varies widely, resulting in much lower THL on most actual phone lines. For applications where THL is a key parameter (such as VOIP applications), it is possible to develop an improved optimization that provides better average THL over the full range of actual phone lines than is provided by a simple 600 ohm optimization.

The AC impedance presented to the phone line has been set to 600 ohms. The two components that dominate the impedance are R4 and the transformer. Changes to either of these components will affect the AC impedance, the transmit/receive gains, and the trans-hybrid loss.

Lightning immunity with the specified components is excellent. Differential lightning surges (tip to ring) are current limited by U2 and shunted through E1. Immunity to common mode lightning (tip/ring to earth ground) is provided by the isolation barrier that passes through T1, U2, and U3.

Layout Guidelines for Both Circuits

- 1) The isolation barrier shown by the black dotted line is a key requirement for regulatory compliance. This barrier can be visualized as a keep-out “moat” around the tip/ring circuits, with only the transformer and the two opto isolators bridging the moat.
- 2) Note that the isolation barrier must be maintained in three dimensions. This means that conductive parts associated with the equipment housing or with other circuit boards should not be placed directly above or below the tip/ring circuits in violation of the isolation barrier distance.
- 3) In the board layout, the width of the isolation barrier can be as small as 1.6 mm and still meet regulatory requirements, but a 5 mm barrier will provide better protection against common mode lightning surges, which can reach 5000 volts in some applications. Aside from the transformer and the two opto isolators, there should be no components, circuit traces, or copper bridging the isolation barrier on any layer.
- 4) The circuitry on the phone line side of the isolation barrier should be grouped together on a small island that is separated from all other circuitry by the isolation barrier. There should be no ground plane under the circuits on the phone line side of the isolation barrier.
- 5) Some of the circuit board traces on the phone line side of the isolation barrier must handle lightning surges up to 100 amps. The section that takes the full lightning surge is the path from the tip lead of the phone jack, through F1, E1, and back to the ring lead of the phone jack. The traces for this path should be a minimum of 15 mils wide (about 0.4 mm) with 15 mil spacing. This value assumes the use of standard 1 ounce copper for the circuit board. Aside from this small subcircuit, traces of 8 mils with 8 mil spacing are adequate.
- 6) Standard analog design practices should be used for the layout of the circuits around the LMV822 op amps. These include short traces for the inverting and non-inverting inputs, good power supply decoupling, and a low noise power supply. An internal ground plane in this area is desirable but not essential.

Additional Enhancements for Either Circuit

Several enhancements can be added to either circuit with some modifications:

+3.3 Volt Operation

The circuits shown here will operate on a 3.3 volt supply, but the output swing available across a 600 ohm load on tip/ring will be reduced to about 1.6 volts peak to peak (down from 2.5 volts peak to peak

with a +5 volt supply). A transmit swing of 1.6 volts peak to peak is adequate for transmitting ITU V.21 and V.22 modem signals at the allowable maximum of -10 dBm, but ITU V.22bis data modems and V.29, V.17, and V.34 fax modems have peak-to-RMS ratios that require greater swing. These modems should be limited to a maximum transmit level of -13 dBm if a single +3.3 volt supply is used. If higher transmit levels or lower supply voltages are desired, the transmit driver can be converted to a differential driver by adding another op amp. This effectively doubles the available output swing. When converting to a differential transmit driver, the transmit gain, receive gain, and trans-hybrid loss must be re-optimized.

Loop Current Detection

In some applications, it is necessary to detect the presence or absence of DC loop current from the central office. For instance, a brief interruption of central office loop current is often used to signal that the far end party has hung up. For voice messaging equipment, detection of this signal can be used to quickly return to the idle state after an incoming message has been completed.

To add loop current detection, an opto isolator can be inserted so that a portion of the loop current flows through its input LED. Care must be taken to ensure that the LED in the opto isolator is adequately protected from surge currents, but there are several possible circuits that will accomplish this.

Caller ID and On-Hook Monitoring

Many applications require some method for monitoring the voiceband AC signal that is present on the phone line during the on-hook state. Examples include caller ID reception, and detection of the CNG tone for automatic voice/fax switching.

For implementing this feature, it is highly desirable to couple the received signal through the transformer. This allows the transformer to provide both lightning protection and immunity from common mode 60 Hz interference. These two impairments often present problems for on-hook monitor implementations that use capacitively coupled differential amplifiers.

It is possible to use the transformer to couple the signals in the on-hook state by placing a bypass capacitor across the switchhook relay and making some other minor modifications to the circuit. Care must be taken in the design of such bypass circuits to avoid affecting compliance with other regulatory requirements such as on hook AC impedance. The options that can be considered will depend on whether the monitoring is only for caller ID signals or is for other signals such as CNG tones, and whether international regulatory compliance is required.

Compliance With Worldwide Regulatory Requirements

As explained in the section on suitability, the wet transformer circuit shown in Figure 1 can be used in most, but not all countries. The only parameter that prevents the wet transformer from being used in certain countries is the AC impedance presented to the phone line (typically specified as return loss).

If the application requires a single design that can be used in any country worldwide, it should be based on the dry transformer circuit in Figure 2. For full worldwide compatibility, the circuit of Figure 2 must be modified to support two different AC impedance settings, with an appropriate means for selecting between them. Alternatively, the AC impedance can be synthesized digitally using a codec that provides this feature.

Summary

Transformer-based DAA and FXO circuits offer excellent performance at a competitive cost for most applications. When properly implemented, they have excellent lightning immunity, power cross immunity, and immunity to conducted RF interference. They have exceptional balance and common mode 60 Hz immunity for applications that require low noise and hum. They are also able to operate very well on low loop current.

These attributes make transformer DAA and FXO circuits worth considering for many applications. In general, silicon DAA and FXO circuits perform less well with regard to one or more of the above parameters, but the silicon versions do have other advantages such as smaller size, more line status sensing features, and more software configurability. Thus, the determination of which type of DAA or FXO circuit is best will depend on the specific needs of the target application.

There are two basic types of transformers used in transformer-based DAA and FXO circuits. The two types are referred to as “wet” transformers and “dry” transformers. Examples of both types of circuits have been provided here, and their characteristics have been compared. In general, the wet transformer circuit offers the lowest cost, but a dry transformer circuit offers smaller size and some performance improvements that may be important for certain applications.

The intent of this article is to describe basic implementations of both types of circuits. If the schematics and layout guidelines provided here are carefully applied, these circuits should perform quite well.

Some applications may require modifications to the designs presented here, such as changes to the transmit and receive gains, trans-hybrid loss optimization, or AC impedance. Also, any substitutions for the specified transformer will require a re-optimization of these parameters. For some applications, additional features may need to be added, such as loop current detection, caller ID detection, or worldwide configurability. For assistance with modifications such as these, contact the author.

About the Author

Joe Randolph is a consultant who specializes in the design of telecommunications equipment. He has extensive experience with the design of analog and digital PSTN interfaces for worldwide applications, and has product designs approved in over 100 countries. His experience with product design includes telephones, modems, voice messaging equipment, fax machines, PBXs, central office line cards, T1/E1, DSL, and internet telephony (VOIP) equipment. If you have questions about the circuits described here, or if you want assistance with a related application, you can contact Mr. Randolph directly:

Joe Randolph
Randolph Telecom, Inc.
Phone: 781-721-2848 (USA)
Email: jpr@randolph-telecom.com
Web Site: <http://www.randolph-telecom.com>

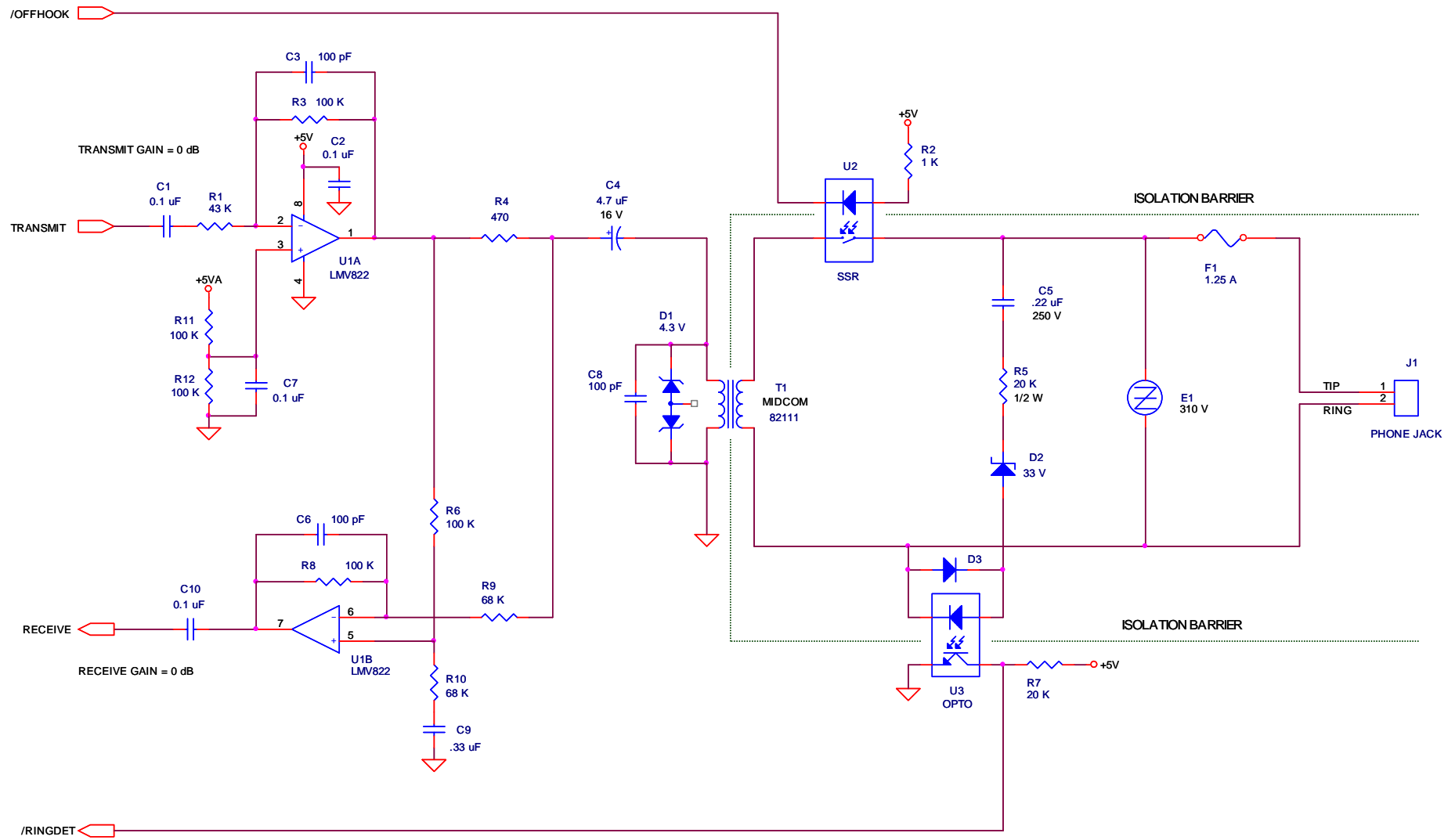

FIGURE 1
 BASIC "WET" TRANSFORMER PHONE LINE INTERFACE CIRCUIT

TABLE 1
WET TRANSFORMER DAA/FXO CIRCUIT
BILL OF MATERIALS
(Reference Figure 1)

Quantity	Reference Designation	Description	Vendor
4	C1,C2,C7,C10	Ceramic cap, 0.1 uF, 25 V, Z5U	Generic
3	C3,C6,C8	Ceramic cap, 100 pF, 25 V, NPO	Generic
1	C4	Aluminum cap, 4.7 uF, 16 V	Generic
1	C5	Ceramic cap, .22 uF, 250 V, Z5U	Generic
1	C9	Ceramic cap, 0.33 uF, 25 V, Z5U	Generic
1	D1	Bidirectional zener, 4.3V, CMPZDA4V3	Central Semi
1	D2	Zener diode, 33V	Generic
1	D3	Signal diode	Generic
1	E1	Thyristor, 310V,TISP4350H3	Bourns
	E1 Alternate	Sidactor, 310V, P3100SC	Littelfuse
1	F1	Fuse, 1.25 amp, 230-1.25, axial	Littelfuse
	F1 Alternate	Fuse, 1.25 amp, C515-1.25, axial	Bussmann
	F1 Alternate	Fuse, 1.25 amp, 0461-1.25, surface mount	Littelfuse
1	R1	43 K, 5%, 1/10 W	Generic
1	R2	1 K, 5%, 1/10 W	Generic
5	R3,R6,R8,R11,R12	100 K, 5%, 1/10 W	Generic
1	R4	470 ohm, 5%, 1/10 W	Generic
1	R5	20 K, 5%, 1/2 W	Generic
1	R7	20 K, 5%, 1/10 W	Generic
2	R9,R10	68 K, 5%, 1/10 W	Generic
1	T1	Transformer, Midcom 82111	Midcom
1	U1	Op amp, LMV822	National Semi
1	U2	Solid-state relay, AD6C111	Solid State Optronics
	U2 Alternate	Solid state relay, PS7341CL-1A	NEC
	U2 Alternate	Solid state relay, LH1540	Vishay
1	U3	Opto-isolator, SDT400-B	Solid State Optronics
	U3 Alternate	Opto-isolator, PS2701	NEC
31	Total Parts Count		

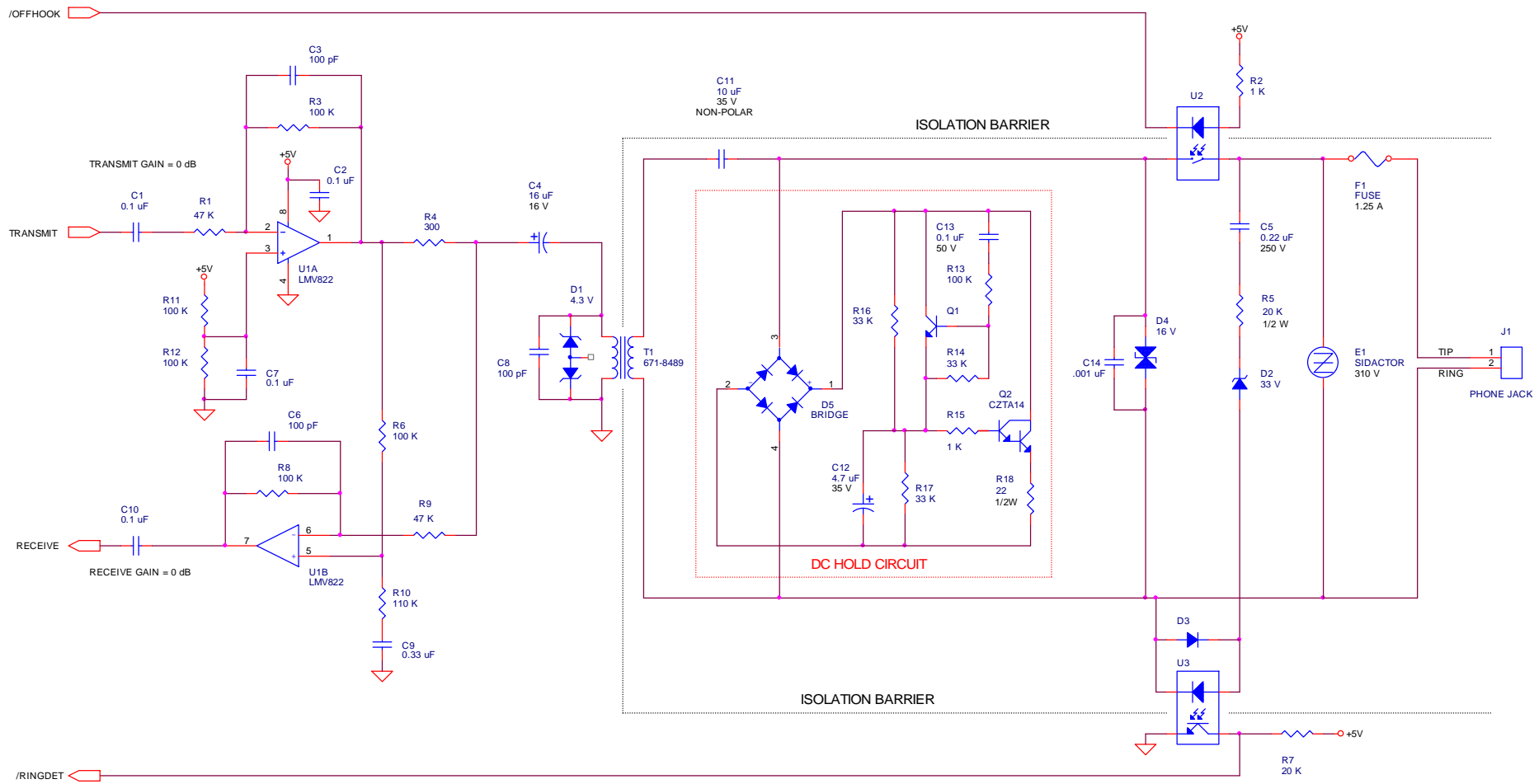

FIGURE 2
BASIC "DRY" TRANSFORMER PHONE LINE INTERFACE

TABLE 2
DRY TRANSFORMER DAA/FXO CIRCUIT
BILL OF MATERIALS
(Reference Figure 2)

Quantity	Reference Designation	Description	Vendor
4	C1,C2,C7,C10	Ceramic cap, 0.1 uF, 25 V, Z5U	Generic
3	C3,C6,C8	Ceramic cap, 100 pF, 25 V, NPO	Generic
1	C4	Aluminum cap, 16 uF, 16 V	Generic
1	C5	Ceramic cap, .22 uF, 250 V, Z5U	Generic
1	C9	Ceramic cap, 0.33 uF, 25 V, Z5U	Generic
1	C11	Aluminum cap, 10 uF, 35V, non-polar	
1	C12	Tantalum cap, 4.7 uF, 35V	
1	C13	Ceramic cap, 0.1 uF, 50V, Z5U	
1	C14	Ceramic cap, .001 uF, 50V	
1	D1	Bidirectional zener, 4.3V, CMPZDA4V3	Central Semi
1	D2	Zener diode, 33V	Generic
1	D3	Signal diode	Generic
1	D4	Surge diode, 16 V, bidirectional, SMAJ16C	General Semi
1	D5	Diode bridge, 0.5 amp, CBRHD-02	Central Semi
1	E1	Thyristor, 310V,TISP4350H3	Bourns
	E1 Alternate	Sidactor, 310V, P3100SC	Littelfuse
1	F1	Fuse, 1.25 amp, 230-1.25, axial	Littelfuse
	F1 Alternate	Fuse, 1.25 amp, C515-1.25, axial	Bussmann
	F1 Alternate	Fuse, 1.25 amp, 0461-1.25, surface mount	Littelfuse
1	Q1	Transistor, NPN, MMBT3904LT1	On Semi
1	Q2	Transistor, NPN Darlington, 2W, CZTA14	Central Semi
2	R1,R9	47 K, 5%, 1/10 W	Generic
2	R2,R15	1 K, 5%, 1/10 W	Generic
6	R3,R6,R8,R11,R12,R13	100 K, 5%, 1/10 W	Generic
1	R4	300 ohm, 5%, 1/10 W	Generic
1	R5	20 K, 5%, 1/2 W	Generic
1	R7	20 K, 5%, 1/10 W	Generic
1	R10	110 K, 5%, 1/10 W	Generic
3	R14,R16,R17	33 K, 5%, 1/10 W	Generic
1	R18	22 ohm, 5%, 1/2 W	
1	T1	Transformer, Midcom 671-8489	Midcom
1	U1	Op amp, LMV822	National Semi
1	U2	Solid-state relay, AD6C111	Solid State Optronics
	U2 Alternate	Solid state relay, PS7341CL-1A	NEC
	U2 Alternate	Solid state relay, LH1540	Vishay
1	U3	Opto-isolator, SDT400-B	Solid State Optronics
	U3 Alternate	Opto-isolator, PS2701	NEC
45	Total Parts Count		